

LASCAR HS C

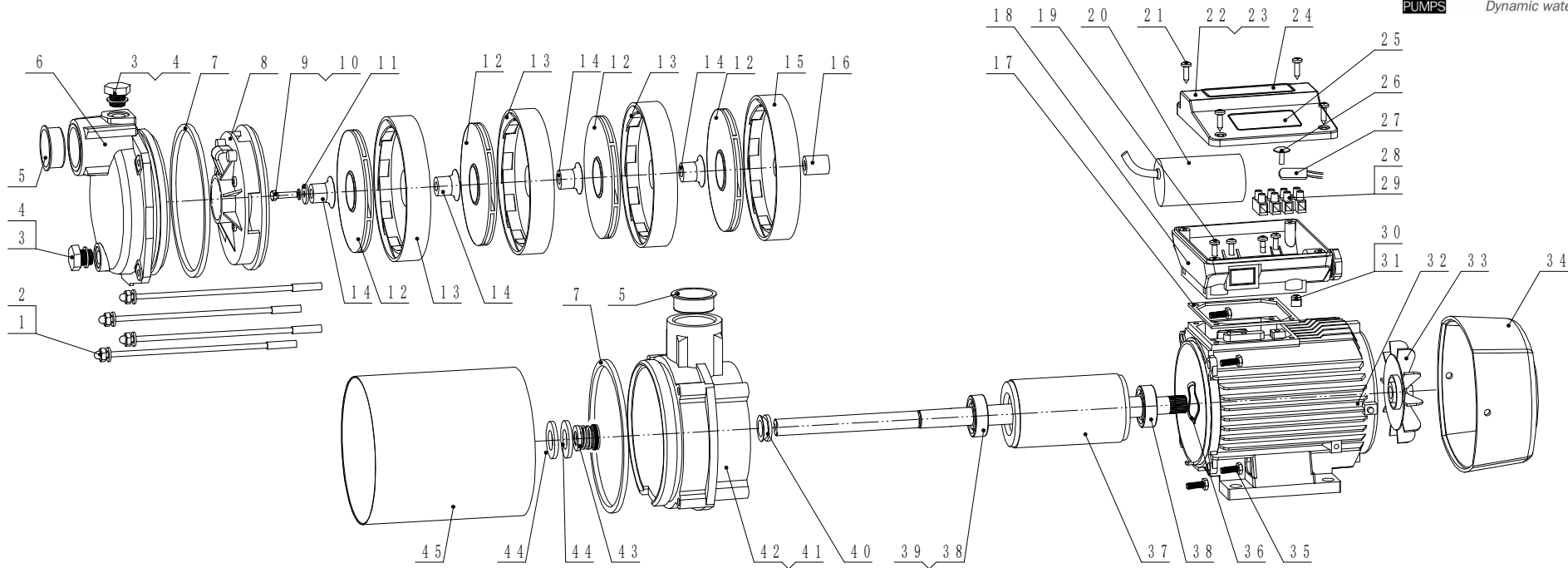

10	gasket	20	capacitor	30	screw	40	ring		
9	screw	19	screw	29	screw	39	ring		
8	diffuser set	18	terminal box	28	terminal block	38	bearing		
7	seal gasket	17	seal	27	protector	37	rotor		
6	pump body	16	shaft sleeve	26		36	gasket		
5		15	diffuser 2	25		35	screw	45	housing
4	seal ring	14	sleeve	24		34	fan cover	44	gasket
3		13	diffuser 1	23		33	fan	43	mechanical seal
2	gasket	12	impeller	22	cover	32	stator	42	
1		11	gasket	21	screw	31	base	41	motor support